

# DIRTY SOUND MAGNET

## Technical Rider

**Technical management**

Marco Mottolini  
+41 79 821 20 01  
[management@dirty\\_soundmagnet.com](mailto:management@dirty_soundmagnet.com)

## General information

This document describes the technical requirements for a venue of at least 200 people. This rider is part of the contract and can be modified at any time.

### Crew

- 3 musicians
- ~~1 sound engineer FOH + technical direction~~  
*(!! Due to COVID-19, we don't have any sound engineer anymore !!)*
- 1 roadie

### Sound check

- 1 hour of stage setup
- 1 hour of sound check and light check on the stage in the dark and without public

### Sound





- Sound system NEXO, L-Acoustics or Meyer Sound (98 dB without distortion and frequency range from 20Hz to 20kHz)
- Console: Midas Heritage, Midas M 32, Midas pro 2, ES FOH or equivalent
- 6 wedges (NEXO 45N12, PS15, PS10 or MTD115) and 4 amplification channels
- Microphones and DI (see patch list section)
- Talk Back
- Front-field if the stage and the system are distant
- 100 dB authorization (if required)

### Stage

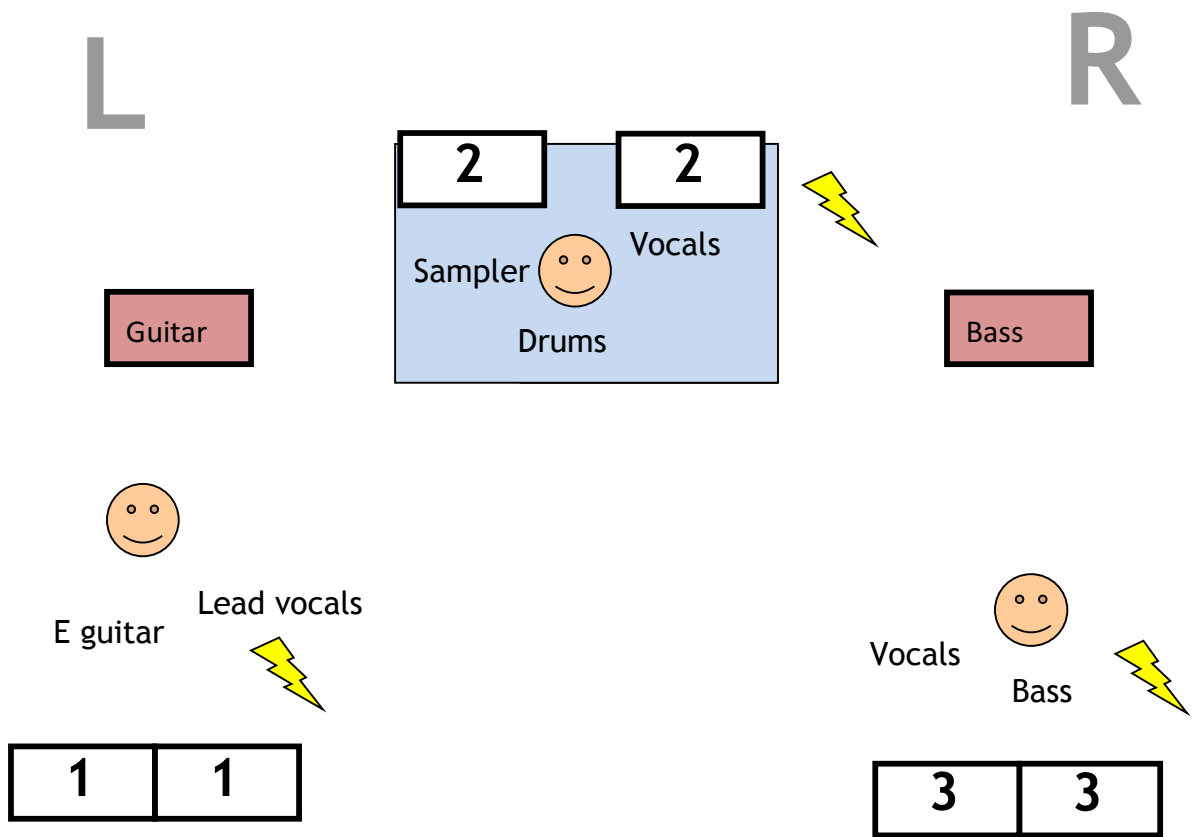
- « Black box » stage
- Professional stage – 750kg/m<sup>2</sup>, 8x8m
- 5 stage decks of 2x1x0.4m for the drums

# Stage plan



	Power 230V/10A
	Monitor
	Amps
	Stage deck 2x3x0.4m

**Patch List** *(As we don't bring our sound engineer along, this is purely informative and the resident sound engineer can do the micing as he wish. The setup is not complicated.)*

Line #	Name	Mic / DI / Line	Stand
1	KK out		Small
2	SN top		Medium
3	Floor Tom		Medium
4	Rack Tom		Big (not straight)
5	OH Left		Small
6	OH Right		Small
7	Pad	DI	
8	Bass 1	DI (own)	-
9	E Guitar 1	Sm57	Medium
10	E Guitar 2	Sm57	Medium
11	Lead vocals GTR	Beta 57 (own mic)	Big (not straight)
12	Vocals Drums	Beta 57 (own mic)	Big (not straight)
13	Vocals Bass	Beta 57 (own mic)	Big (not straight)
	VCA or DCA 1	Drums	
	VCA or DCA 2	Loop	
	VCA or DCA 3	Bass	
	VCA or DCA 4	Guitar	
	VCA or DCA 5	Vocals Lead	
	VCA or DCA 6	Vocals Back	
	VCA or DCA 7	Instruments	
	Group comp.	Drums	
	Delay		
	Plate		
	Hall/Room		
	Chorus		
	Flange		
	Overdrive		
	Slapback		